

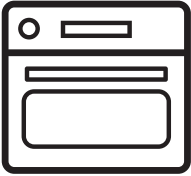

Electrolux



[electrolux.com/register](https://electrolux.com/register)



EN User Manual | **Microwave combi-oven**

**EVLBE08GX**



# INSTALLATION

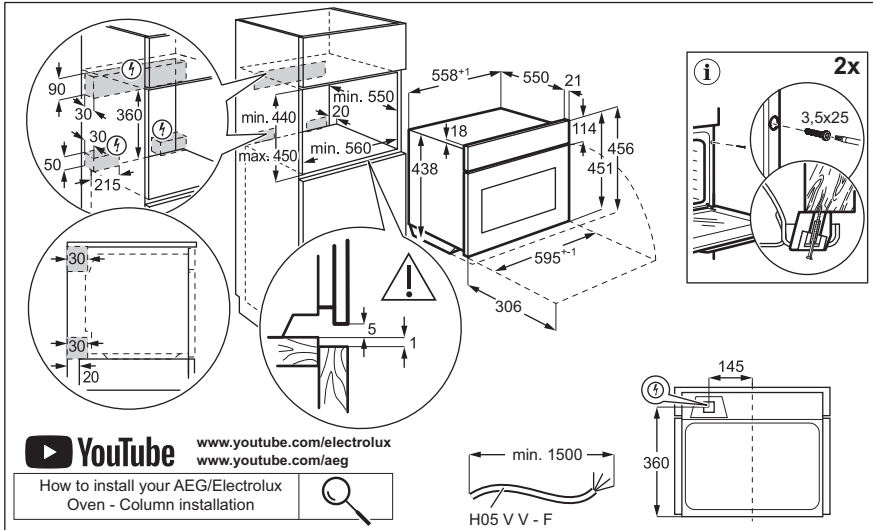
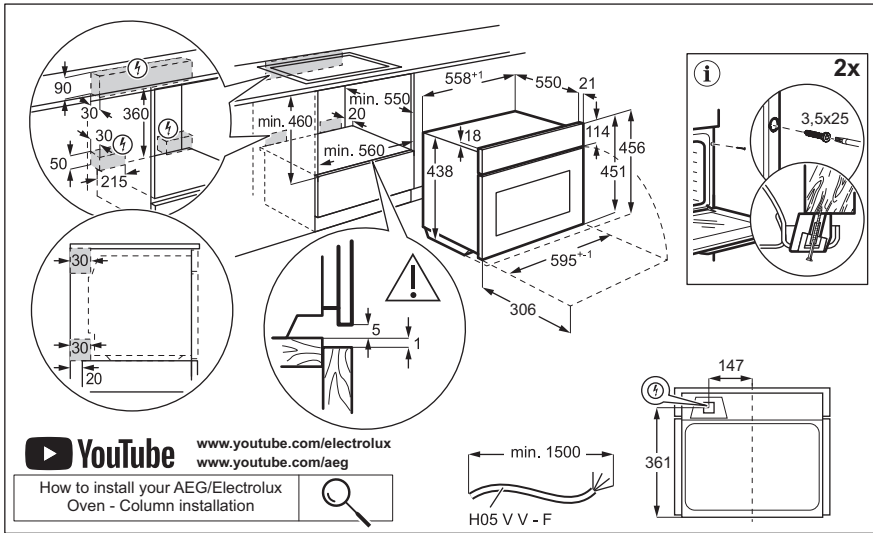

# Welcome to Electrolux! Thank you for choosing our appliance.



Get usage advice, brochures, troubleshooting, service and repair information:  
[www.electrolux.com/support](http://www.electrolux.com/support)

Subject to change without notice.

## CONTENTS

1. SAFETY INFORMATION.....	3
2. SAFETY INSTRUCTIONS.....	6
3. PRODUCT DESCRIPTION.....	8
4. CONTROL PANEL.....	9
5. BEFORE FIRST USE.....	10
6. DAILY USE.....	10
7. ADDITIONAL FUNCTIONS.....	13
8. CLOCK FUNCTIONS.....	14
9. USING THE ACCESSORIES.....	15
10. HINTS AND TIPS.....	16
11. CARE AND CLEANING.....	20
12. TROUBLESHOOTING.....	21
13. ENERGY EFFICIENCY.....	22
14. ENVIRONMENTAL CONCERNS.....	23

## 1. ⚠ SAFETY INFORMATION

Before the installation and use of the appliance, carefully read the supplied instructions. The manufacturer is not responsible for any injuries or damage that are the result of incorrect installation or usage. Always keep the instructions in a safe and accessible location for future reference.

### 1.1 Children and vulnerable people safety

- This appliance can be used by children aged from 8 years and above and persons with reduced physical, sensory or mental capabilities or lack of experience and knowledge if they have been given supervision or instruction concerning the use of the appliance in a safe way and understand the hazards involved. Children of less than 8 years of age and persons with very extensive and complex disabilities shall be kept away from the appliance unless continuously supervised.

- Children should be supervised to ensure that they do not play with the appliance.
- Keep all packaging away from children and dispose of it appropriately.
- **WARNING:** The appliance and its accessible parts become hot during use. Keep children and pets away from the appliance when in use and when cooling down.
- If the appliance has a child safety device, it should be activated.
- Children shall not carry out cleaning and user maintenance of the appliance without supervision.

## **1.2 General Safety**

- This appliance is for cooking purposes only.
- This appliance is designed for single household domestic use in an indoor environment.
- This appliance may be used in offices, hotel guest rooms, bed & breakfast guest rooms, farm guest houses and other similar accommodation where such use does not exceed (average) domestic usage levels.
- Only a qualified person must install this appliance and replace the cable.
- Do not use the appliance before installing it in the built-in structure.
- Disconnect the appliance from the power supply before carrying out any maintenance.
- If the supply cord is damaged, it must be replaced by the manufacturer, its Authorised Service Centre or similarly qualified persons to avoid an electrical hazard.
- **WARNING:** Ensure that the appliance is switched off before replacing the lamp to avoid the possibility of electric shock.
- **WARNING:** The appliance and its accessible parts become hot during use. Care should be taken to avoid touching heating elements or the surface of the appliance cavity.
- Always use oven gloves to remove or insert accessories or ovenware.

- Do not activate the microwave function when the appliance is empty. Metal parts inside the cavity can create electric arcing.
- Metallic containers for food and beverages are not allowed during microwave cooking. This requirement is not applicable if the manufacturer specifies size and shape of metallic containers suitable for microwave cooking.
- **WARNING:** If the door or door seals are damaged, the appliance must not be operated until it has been repaired by a qualified person.
- **WARNING:** Only a qualified person can carry out any service or repair operation that involves the removal of a cover which gives protection against exposure to microwave energy.
- **WARNING:** Do not heat liquids and other foods in sealed containers. They are liable to explode.
- Use only utensils that are suitable for use in microwave ovens.
- When heating food in plastic or paper containers, observe the appliance due to the possibility of ignition.
- The appliance is intended for heating food and beverages. Drying of food or clothing and heating of warming pads, slippers, sponges, damp cloth and similar may lead to risk of injury, ignition or fire.
- If smoke is emitted, switch off or unplug the appliance and keep the door closed in order to stifle any flames.
- Microwave heating of beverages can result in delayed eruptive boiling. Care must be taken when handling the container.
- The contents of feeding bottles and baby food jars shall be stirred or shaken and the temperature checked before consumption, in order to avoid burns.
- Eggs in their shell and whole hard-boiled eggs should not be heated in the appliance since they may explode, even after microwave heating has ended.

- To remove the shelf supports first pull the front of the shelf support and then the rear end away from the side walls. Install the shelf supports in the opposite sequence.
- The appliance should be cleaned regularly and any food deposits removed.
- Do not use a steam cleaner to clean the appliance.
- Do not use harsh abrasive cleaners or sharp metal scrapers to clean the glass door since they can scratch the surface, which may result in shattering of the glass.
- Failure to maintain the appliance in a clean condition could lead to deterioration of the surface that could adversely affect the life of the appliance and possibly result in a hazardous situation.

## 2. SAFETY INSTRUCTIONS

### 2.1 Installation

#### **WARNING!**

Only a qualified person must install this appliance.

- Remove all the packaging.
- Do not install or use a damaged appliance.
- Follow the installation instructions available on our website.
- Always take care when moving the appliance as it is heavy. Always use safety gloves and enclosed footwear.
- Do not pull the appliance by the handle.
- Install the appliance in a safe and suitable place that meets installation requirements.
- Keep the minimum distance from other appliances and units.
- Before mounting the appliance, check if the appliance door opens without restraint.
- The appliance is equipped with an electric cooling system. It must be operated with the electric power supply.

### 2.2 Electrical connection

#### **WARNING!**

Risk of fire and electric shock.

- All electrical connections should be made by a qualified electrician.
- The appliance must be earthed.
- Make sure that the parameters on the rating plate are compatible with the electrical ratings of the mains power supply.
- Always use a correctly installed shockproof socket.
- Do not use multi-plug adapters and extension cables.
- Make sure not to cause damage to the mains plug and to the mains cable. Should the mains cable need to be replaced, this must be carried out by our Authorised Service Centre.
- Do not let mains cables touch or come near the appliance door or the niche below the appliance, especially when it operates or the door is hot.
- The shock protection of live and insulated parts must be fastened in such a way that it cannot be removed without tools.
- Connect the mains plug to the mains socket only at the end of the installation. Make sure that there is access to the mains plug after the installation.
- If the mains socket is loose, do not connect the mains plug.
- Do not pull the mains cable to disconnect the appliance. Always pull the mains plug.

- Use only correct isolation devices: line protecting cut-outs, fuses (screw type fuses removed from the holder), earth leakage trips and contactors.
- The electrical installation must have an isolation device which lets you disconnect the appliance from the mains at all poles. The isolation device must have a contact opening width of minimum 3 mm.
- This appliance is supplied only with a main cable.

## 2.3 Use

### **WARNING!**

Risk of injury, burns and electric shock or explosion.

- Do not change the specification of this appliance.
- Make sure that the ventilation openings are not blocked.
- Do not let the appliance stay unattended during operation.
- Deactivate the appliance after each use.
- Be careful when you open the appliance door while the appliance is in operation. Hot air can be released.
- Do not operate the appliance with wet hands or when it comes in contact with water.
- Do not apply pressure on the open door.
- Do not use the appliance as a work surface or as a storage surface.
- Open the appliance door carefully. The use of ingredients with alcohol can cause a mixture of alcohol and air.
- Do not let sparks or open flames to come in contact with the appliance when you open the door.
- Do not put flammable products or items moistened with flammable products in, near or on the appliance.
- Do not use microwave function to preheat the appliance.

### **WARNING!**

Risk of damage to the appliance.

- To prevent damage or discolouration to the enamel:
  - do not put aluminium foil directly on the bottom of cavity of the appliance.

- do not put water directly into the hot appliance.
- do not keep moist dishes and food in the appliance after you finish the cooking.
- be careful when you remove or install the accessories.
- Discolouration of the enamel or stainless steel has no effect on the performance of the appliance.
- Use a deep pan for moist cakes. Fruit juices cause stains that can be permanent.
- Use only accessories supplied with this appliance or recommended by the manufacturer.
- Always cook with the appliance door closed.
- If the appliance is installed behind a furniture panel (e.g. a door) make sure the door is never closed when the appliance operates. Heat and moisture can build up behind a closed furniture panel and cause subsequent damage to the appliance, the housing unit or the floor. Do not close the furniture panel until the appliance has cooled down completely after use.

## 2.4 Care and cleaning

### **WARNING!**

Risk of injury, fire, or damage to the appliance.

- Before maintenance, deactivate the appliance and disconnect the mains plug from the mains socket.
- Make sure the appliance is cold. There is the risk that the glass panels can break.
- Replace immediately the door glass panels when they are damaged. Contact the Authorised Service Centre.
- Make sure the cavity and the door are wiped dry after each use. Steam produced during the operation of the appliance condensates on cavity walls and can cause corrosion.
- Clean regularly the appliance to prevent the deterioration of the surface material.
- Fat and food remaining in the appliance can cause fire and electric arcing when the microwave function operates.

- Clean the appliance with a moist soft cloth. Use only neutral detergents. Do not use abrasive products, abrasive cleaning pads, solvents or metal objects.
- If you use an oven spray, follow the safety instructions on its packaging.

## 2.5 Internal lighting

### **⚠ WARNING!**

Risk of electric shock.

- Concerning the lamp(s) inside this product and spare part lamps sold separately: These lamps are intended to withstand extreme physical conditions in household appliances, such as temperature, vibration, humidity, or are intended to signal information about the operational status of the appliance. They are not intended to be used in other applications and are not suitable for household room illumination.

- This product contains a light source of energy efficiency class G.
- Use only lamps with the same specifications.

## 2.6 Service

- To repair the appliance contact the Authorised Service Centre.
- Use original spare parts only.

## 2.7 Disposal

### **⚠ WARNING!**

Risk of injury or suffocation.

- Contact your municipal authority for information on how to dispose of the appliance.
- Disconnect the appliance from the mains supply.
- Cut off the mains electrical cable close to the appliance and dispose of it.

## 3. PRODUCT DESCRIPTION

### 3.1 General overview

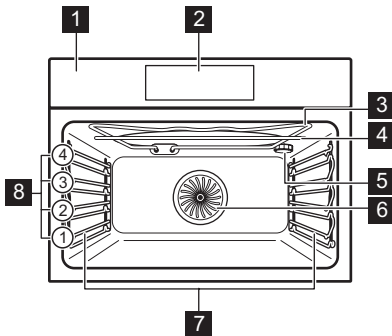

- 1** Control panel
- 2** Display
- 3** Heating element
- 4** Microwave generator
- 5** Lamp
- 6** Fan
- 7** Shelf support, removable
- 8** Shelf positions

## 4. CONTROL PANEL

### 4.1 Control panel overview

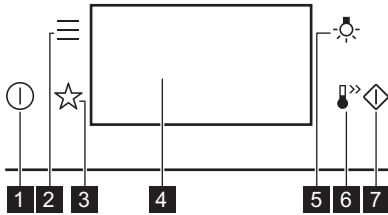

**1 ON / OFF**  
Press and hold to turn the appliance on and off.

**2 Menu**  
Lists the appliance options and setting functions.

**3 Favourites**  
Lists the favourite settings.

**4 Display**  
Shows the current settings of the appliance.

**5 Lamp switch**  
To turn the lamp on and off.

**6 Fast Heat Up**  
To turn on and off the function: Fast Heat Up.

**7 Microwave quick start**  
To turn on microwave function (1000 W and 30 seconds).

### 4.2 Display

Display with key functions set.

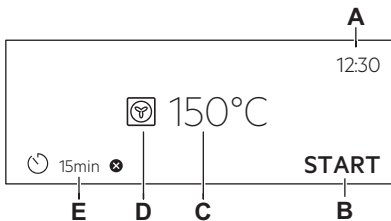

- A. Time of Day
- B. START / STOP
- C. Temperature / Microwave timer
- D. Heating functions
- E. Timer

#### Display indicators

**OK** To confirm the selection / setting.

**<** To go one level back in the menu.

**↶** To undo the last action.

**⏻** To turn the options on and off.

**🔒** The appliance is locked.

**🔔** The sound alarm function is activated.

**🔔 STOP** The sound alarm and stop cooking function is activated.

**🔔** Pop up message only is activated.

**🕒** Delayed start function is activated.

**✖** To cancel the setting.



The display shows various messages. When a message window appears, press the display to continue.

## 5. BEFORE FIRST USE

### **WARNING!**

Refer to Safety chapters.

### 5.1 First connection



The display shows welcome message after the first connection.

You have to set: Language, Display Brightness, Key Tones, Buzzer Volume, Time of Day.

### 5.2 Initial preheating and cleaning

Preheat the empty appliance before the first use and contact with food. The appliance can emit unpleasant smell and smoke. Ventilate the room during preheating.

1. Remove all accessories and removable shelf supports from the appliance.

2. Set the function . Set the maximum temperature. Refer to Daily use. Let the appliance operate for 1 h.
3. Set the function . Set the maximum temperature. Let the appliance operate for 15 min.
4. Set the function . Set the maximum temperature. Let the appliance operate for 15 min.
5. Turn off the appliance and wait until it is cold.
6. Clean the appliance and the accessories only with a microfibre cloth, warm water and a mild detergent.
7. Put the accessories and removable shelf supports back to their initial position.

## 6. DAILY USE

### **WARNING!**

Refer to Safety chapters.

### 6.1 Heating functions

#### STANDARD



#### **Grill**

To grill thin pieces of food and to toast bread.



#### **Turbo Grilling**

To roast large meat joints or poultry with bones on one shelf position. To bake gratins and to brown.



#### **True Fan Cooking**

To roast meat and bake cakes. Set a lower temperature than for Conventional Cooking as the fan distributes heat evenly in the oven interior.



#### **Frozen Foods**

Perfect for ready meals (e.g. french fries, croquettes or spring rolls).



#### **Conventional Cooking**

To bake and roast food on one shelf position.



#### **Pizza Function**

To bake pizza and other dishes that require more heat from below.



#### **Bottom Heat**







Choose this function after a cooking process to brown the food more on the bottom if needed. Use the lowest shelf level.

#### SPECIALS









#### **Preserving**





To preserve vegetables and fruits, place canning jars in a baking tray filled with water, using heat-resistant jars with bayonet or screw caps of the same size. Use the lowest shelf position.

	<b>Dehydrating</b> To dry sliced fruit, vegetables and mushrooms. To allow the moisture-saturated air to escape and the fruit to dry better, it is advisable to open the oven door occasionally during the drying process.
	<b>Plate Warming</b> To preheat plates for serving.
	<b>Dough Proving</b> To speed up the rising of the yeast dough. Cover the surface of the dough to prevent from drying.
	<b>Au Gratin</b> For dishes such as lasagna or potato gratin. To bake gratins and to brown.
	<b>Slow Cooking</b> Low temperature cooking process. It's perfect to cook delicate food (e.g., beef, veal or lamb). For a richer flavour and better browning, sear the meat before placing it in the oven.
	<b>Keep Warm</b> To keep food warm. Please note that some dishes may continue to cook and dry out while being kept warm. Cover the dishes if necessary.
	<b>Bread Baking</b> Use this function to prepare bread and bread rolls with professional-like result in terms of crispiness, colour and crust gloss.

## MICROWAVE

	<b>Microwave</b> Heating up, cooking, power range: 100 - 1000 W
	<b>Defrost</b> Defrosting various types of food, power range: 100 - 200 W
	<b>Reheat</b> Heating up pre-prepared meals, power range: 300 - 700 W
	<b>Popcorn</b> Preparing popcorn bags, power range: 600 - 800 W
	<b>Melting</b> Melting chocolate and butter, power range: 100 - 400 W
	<b>Liquid</b> Heating up drinks and soups, power range: 600 - 1000 W

## MICROWAVE COMBINATION

	<b>True Fan Cooking + MW</b> Baking on one shelf position. The function with MW boost, power range: 100 - 400 W.
	<b>Conventional Cooking + MW</b> Baking and roasting food on one shelf position. The function with MW boost, power range: 100 - 400 W.
	<b>Grill + MW</b> To grill and brown food on one shelf position. Function with MW boost, power range: 100 - 400 W.
	<b>Turbo Grilling + MW</b> To roast large pieces of meat on one shelf position. To bake gratins and to brown. The function with MW boost, power range: 100 - 400 W.

For general energy saving recommendations refer to "Energy Efficiency" chapter, Energy saving tips.

### 6.2 Setting: Heating functions

1. Turn on the appliance. The display shows the default heating function and the temperature.
2. Press the symbol of the heating function  to enter the submenu.
3. Select the heating function and press **OK**.
4. Set the temperature. Press **OK**.
5. Press **START**.
6. **STOP** - press to turn off the heating function.
7. Turn off the appliance.



The lamp may turn off automatically at a temperature below 80°C during some heating functions.

### 6.3 Setting: Microwave functions

1. Remove all accessories, except the wire shelf.
2. Turn on the appliance.
3. Press the symbol of the heating function to enter the submenu.
4. Select the microwave heating function and press **OK**.

5. Set the microwave power. Press **OK**.
6. Press **START**.
7. **STOP** - press to turn off the heating function.
8. Turn off the appliance.



If you open the door, the function stops.  
To start it again, press **START**.

## 6.4 Setting: Microwave combination functions

Microwave combination functions combine standard heating functions with microwave boost to shorten cooking time and improve cooking results.

1. Turn on the appliance. The display shows the default heating function and the temperature.
2. Press the symbol of the heating function  to enter the submenu.
3. Select the microwave combination function and press **OK**. The display shows the temperature.
4. Set the temperature. Press **OK**.
5. Press: **W**. The display shows the microwave power settings.
6. Set the microwave power. Press **OK**.
7. Press **START**.
8. **STOP** - press to turn off the heating function.
9. Turn off the appliance.

## 6.5 Setting: Microwave quick start

The microwave can be turned on at any time with: Microwave quick start.

1. Press and hold . The microwave runs for 30 sec with the maximum power.
2. Press on the running time value or press **+30 s** to extend the cooking time.
3. Press **OK**.

## 6.6 Menu

Press  to enter the menu.

Menu item		Description
Assisted Cooking		Lists automatic programmes.
Favourites		Lists the favourite settings.
Options		To set the appliance configuration.
Settings	Setup	To set the appliance configuration.
	Service	Shows the software version and configuration.

### Submenu for: Options

Submenu	Description
Light	Turns the lamp on and off.
Child Lock	Prevents accidental activation of the appliance.
Fast Heat Up	Shortens the heat up time. It is available only for some of the heating functions.
Digital Clock Style	Changes the format of the displayed time indication.

### Submenu for: Settings

#### Setup

Submenu	Description
Language	Sets the appliance language.
Display Brightness	Sets the display brightness.
Key Tones	Turns the tone of the touch fields on and off. It is not possible to mute the tone for  .
Buzzer Volume	Sets the volume of key tones and signals.
Time of Day	Sets the current time and date.

#### Service



Submenu	Description
Demo Mode	Activation / deactivation code: 2468
Software Version	Information about software version.

Submenu	Description
Reset All Settings	Restores factory settings.

## 6.7 Setting: Assisted Cooking

Assisted Cooking submenu consists of a set of additional functions and programs that are designed for dedicated dishes. Each dish in this submenu is provided with a suitable setting. You can adjust the time, temperature and if available microwave power during cooking.

For some of the dishes you can also cook with Weight Automatic.

1. Turn on the appliance.
2. Press .
3. Press . Enter Assisted Cooking.
4. Choose a dish or a food type.
5. Place the food inside the appliance and press START .

When the function ends, check if the food is ready. Extend the cooking time, if needed.

## 7. ADDITIONAL FUNCTIONS

### 7.1 Favourites

You can save up to 3 of your favourite settings, such as heating function and cooking time.

1. Turn on the appliance.
2. Select the preferred setting.
3. Press .
4. Select: Favourites / Save current settings.
5. Press + to add the setting to the list of Favourites.



6. Press OK.



 - press to reset the setting.

 - press to cancel the setting.

### 7.2 Function lock

This function prevents an accidental change of the appliance function.

1. Turn on the appliance.
2. Set a heating function.
3. ,  - press at the same time to turn on the function.

,  - press at the same time to turn off the function.

### 7.3 Child Lock

This function prevents accidental activation of the appliance.

1. Turn on the appliance.
2. Press .

3. Select Options / Child Lock.
4. Press the code letters in an alphabetical order.
5. Turn off the appliance.

Child Lock is activated.



Access to: Timer and lamp is available.

To enable the use of the appliance, press the code letters in an alphabetical order.

To deactivate this function repeat the above steps.

### 7.4 Automatic switch-off

For safety reasons, if the heating function is active and no settings are changed, the appliance will turn off automatically after a certain period of time.

 (°C)	 (h)
30 - 115	12.5
120 - 195	8.5
200 - 230	5.5

If you intend to run a heating function for a duration exceeding the automatic switch-off time, set the cooking time. Refer to Clock functions.

The Automatic switch-off does not work with the functions: Light, End time.

## 7.5 Cooling fan

When the appliance operates, the cooling fan turns on automatically to keep the surfaces of

the appliance cool. If you turn off the appliance, the cooling fan can continue to operate until the appliance cools down.

## 8. CLOCK FUNCTIONS

### 8.1 Clock functions description

Function	Description
Timer	To set the length of cooking. Maximum is 23 h 59 min. You can set what happens when the time is up by setting the preferred: End Action.
End Action	Sound Alarm - when the time is up the signal sounds. You can set this function at any time, even when the appliance is turned off.  Sound Alarm and stop cooking - when the time is up the signal sounds and the heating function turns off. Not available for microwave functions.  Pop up message only - when the time is up the message appears on the display. You can set this function at any time, even when the appliance is turned off.
Delayed start	To postpone the start and / or end of cooking. Not available for microwave functions.
Time Extension	To extend the cooking time.
Uptimer	To show how long the appliance operates. Maximum is 23 h 59 min. You can turn the function on and off. This function has no effect on the operation of the appliance.

### 8.2 Setting: Time of Day

1. Turn on the appliance.
2. Press: Time of Day.
3. Set the time.
4. Press **OK**.

### 8.3 Setting: Timer

1. Choose the heating function and set the temperature.
2. Press .

3. Set the time.



You can select the preferred End action by pressing ● ● ● .

4. Press **OK**. Repeat the action until the display shows the main screen.  
When 10% of cooking time is left and the food does not seem to be ready, you can extend cooking time. You can also change the heating function. Press **+1min** to extend the cooking time.

### 8.4 Setting: Delayed start

1. Set the heating function and the temperature.
2. Press .
3. Set the cooking time.
4. Press ● ● ● .
5. Press: Delayed start.
6. Choose the desired start time.
7. Press **OK**. Repeat the action until the display shows the main screen.

### 8.5 Setting: Uptimer

1. Press .
2. Press ● ● ● .
3. Press: Uptimer.
4. Slide or press  to show the running time on the main screen.
5. Press **OK**. Repeat the action until the display shows the main screen.

### 8.6 Changing timer settings

You can change the set time during cooking at any time.

1. Press .
2. Set the timer value.
3. Press **OK**.

## 9. USING THE ACCESSORIES

### **WARNING!**

Refer to Safety chapters.

### 9.1 Inserting accessories

Accessories available depending on model. Scan the QR code to check how to use accessories supplied with your appliance. You can order optional accessories separately. For more information, please contact your local supplier.



Use only suitable cookware and material. Refer to "Hints and tips" chapter, Microwave suitable cookware and materials.

A small indentation at the top increases safety and provides tilt protection. The indentations are also anti-tip devices. The rim around the shelf prevents cookware from slipping off the shelf.

Insert the accessory (wire shelf / tray) between the guide bars of the shelf support. Make sure that the shelf touches the back of the oven interior and the feet point down.

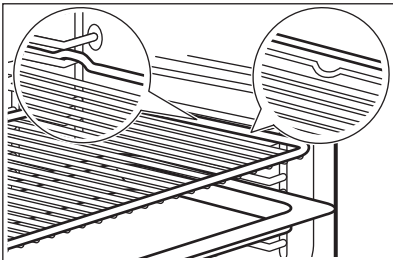

If your tray has a slope, position it towards the back of the oven interior.

If your wire shelf has a step, position it towards the front of the oven interior.

If there is an inscription on the accessory, make sure it is facing you.

If you are using a tray with holes place the tray / pan underneath, to collect dripping liquids.

### 9.2 Trivet and Grill- / Roasting pan

#### **WARNING!**

Be careful when you remove the accessories from a hot appliance. There is a risk of burns.

You can use the trivet to roast larger pieces of meat or poultry on one shelf position.

1. Put the trivet into the deep pan so that the supports of the wire shelf point up.

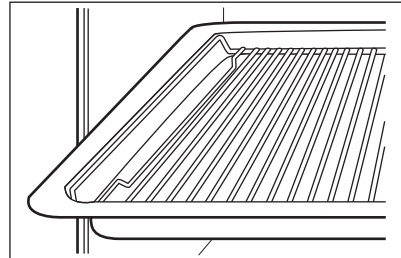

2. Put the deep pan into the appliance on the necessary shelf position.

You can use the trivet to grill flat dishes in large quantities and to toast.

1. Put the trivet into the deep pan so that the supports of the wire shelf point down.

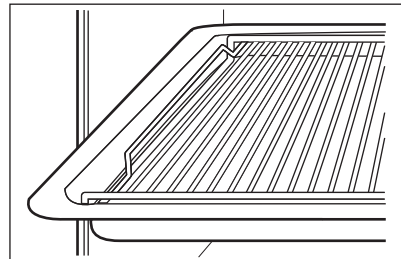

2. Put the deep pan into the appliance on the necessary shelf position.

## 10. HINTS AND TIPS

### 10.1 Cooking recommendations

Cooking and baking processes are only suitable on one level.

The temperature and cooking times in the tables are for guidance only. They depend on the recipes, quality and quantity of the ingredients used.





Your appliance may bake or roast differently than your previous appliance. The hints below show recommended settings for temperature, cooking time and shelf position for specific types of food.

Count the shelf positions from the bottom of the oven floor.

If you cannot find the settings for a specific recipe, look for a similar one.

For energy saving tips refer to Energy efficiency.







#### Symbols used in the tables:





	Food type
	Heating function
	Temperature
	Accessory

### 10.3 Information for test institutes

#### Baking on one level

Tests according to: EN 60350-1, IEC 60350-1.

					
Small cakes, 20 per tray <sup>1)</sup>	Conventional Cooking	Baking tray <sup>2)3)</sup>	2	150	18 - 28
Small cakes, 20 per tray <sup>1)</sup>	True Fan Cooking	Baking tray <sup>2)3)</sup>	2	150	18 - 28
Fatless sponge cake <sup>1)</sup>	Conventional Cooking	Wire shelf	1	170	25 - 35
Fatless sponge cake <sup>1)</sup>	True Fan Cooking	Wire shelf	1	170	28 - 38
Shortbread <sup>1)</sup>	Conventional Cooking	Baking tray <sup>2) 3)</sup>	2	140	28 - 38
Shortbread <sup>1)</sup>	True Fan Cooking	Baking tray <sup>2) 3)</sup>	2	140	25 - 35





	Weight (kg)
	Microwave power (W)
	Shelf position
	Cooking time (min)

### 10.2 Slow Cooking

This function allows you to prepare lean, tender pieces of meat and fish. Use the Food Sensor to measure temperature inside the food. Refer to the table below to find the recommended appliance temperature setting °C that will allow you to achieve the desired temperature inside the food  °C

For roasting flavour and colour, fry the meat in a hot pan for several minutes before inserting it to the appliance. Put the food in the roasting dish and place it on a wire shelf.

	°C
< 65	90
66 - 75	110
> 75	150





				°C	
Apple pie <sup>4)</sup>	Conventional Cooking	Wire shelf	1	170	65 - 75
Apple pie <sup>4)</sup>	True Fan Cooking	Wire shelf	1	170	57 - 67
Toast <sup>1) 5)</sup>	Grill	Wire shelf	2	230	7 - 12

- 1) Preheat the appliance until set temperature is reached. Do not use the function: Fast Heat Up.
- 2) Use baking tray with the slope towards the back of the oven interior.
- 3) Baking tray must touch the back of the oven interior.
- 4) 2 tins placed diagonally (Ø 20 cm). The right one to be positioned more in the front than the left one.
- 5) According to: IEC 60350-1:2016 and IEC 60350-1:2023.

### Microwave and microwave combi functions







Tests according to: EN 60705, IEC 60705.







Use wire shelf. It must touch the back of the oven interior.

			°C		
Sponge cake <sup>1)</sup>	Microwave	500	-	1	8 - 10
Meatloaf <sup>1)2)</sup>	Microwave	300	-	1	30 - 35
Egg custard <sup>3)</sup>	Microwave	400	-	1	18 - 23
Defrosting minced meat (500 g) <sup>4)</sup>	Microwave	200	-	1	7 - 8
Cake <sup>3)</sup>	Conventional Cooking + MW	200	170	1	22 - 27
Potato gratin <sup>5)</sup>	Turbo Grilling + MW	200	180	1	35 - 40
Chicken (1100 g) <sup>6)</sup>	Turbo Grilling + MW	200	200	1	30
	Turbo Grilling	-			18 - 23

- 1) Turn container around by 1/2, halfway through the cooking time.
- 2) Use MW suitable clingfilm during cooking. Prick the clingfilm several times before cooking.
- 3) Do not turn the food during the cooking process.
- 4) Turn the meat upside down over the longest side, one time after 1/3 and a second time after 2/3 of the elapsed cooking time.
- 5) Turn container clockwise by 1/4, halfway through the cooking time.
- 6) Place a plate at the bottom of the oven. Place chicken directly on wire shelf with breast side down. After 30 min, turn the chicken upside down and change the heating function to: Turbo Grilling.

### Additional recipes

					°C	
Meringues <sup>1)</sup>	Conventional Cooking	Baking tray <sup>2)3)</sup>	2	-	100	90 - 180

						
Meringues <b>1)</b>	True Fan Cooking	Baking tray <b>2)3)</b>	2	-	100	90 - 180
Scones <b>1)</b>	Conventional Cooking	Baking tray <b>2)</b>	3	-	200	11 - 13
Scones <b>1)</b>	True Fan Cooking	Baking tray <b>2)</b>	3	-	190	10 - 12
Chicken <b>4)</b>	Turbo Grilling	Baking tray <b>2)</b>	1	-	200	65 - 75
Popcorn <b>5)</b>	Microwave	Flat ceramic plate	bottom	700	-	3 - 4
Plated meals, chilled (1 portion) <b>6) 7)</b>	Microwave	Wire shelf <b>8)</b>	1	500	-	7 - 9
Liquids in baby bottles <b>9)</b>	Microwave	-	bottom	1000	-	0.5
Lasagne, frozen (400 g) <b>10)</b>	Turbo Grilling + MW	Wire shelf <b>8)</b>	1	100	210	23 - 28
Lasagne, frozen (600 g) <b>10)</b>	Conventional Cooking + MW	Wire shelf <b>8)</b>	1	200	190	48 - 53
Pizza, frozen <b>10)</b>	Conventional Cooking + MW	Wire shelf <b>8)</b>	1	200	210	12 - 16
Grilled vegetables, mixed	Turbo Grilling + MW	Wire shelf <b>8)</b>	1	300	180	20 - 25
Roast pork	True Fan Cooking + MW	Wire shelf <b>8)</b>	1	300	165	65 - 70
Stuffed mushrooms	Turbo Grilling + MW	Wire shelf <b>8)</b>	1	300	180	12 - 17
Lasagne with dry pasta sheets	Conventional Cooking + MW	Wire shelf <b>8)</b>	1	200	165	30 - 35

**1)** Preheat the appliance until set temperature is reached. Do not use the function: Fast Heat Up.

**2)** Use baking tray with the slope towards the back of the oven interior.

**3)** Use baking paper.

**4)** Place chicken with breast side down. Turn it upside down halfway through the cooking time.

**5)** The bag should be taken out of the appliance when the kernels stop popping.

**6)** Cover the food with a microwavable plastic lid.

**7)** Turn container around by 1/2, halfway through the cooking time.

**8)** Wire shelf must touch the back of the oven interior.

**9)** Position the bottle in the centre of the cavity bottom without using any accessories.

**10)** Do not turn the food during the cooking process.

## 10.4 Microwave recommendations

Place the food in the centre of the wire shelf.  
Use first shelf position.

Turn or stir the food halfway through the cooking time to improve the results.

Stir liquid dishes from time to time.

Stir the food before serving.

Put the spoon into the cup or glass when heating up liquids, to improve heat distribution and avoid overboiling. The spoon

must not touch any part of the oven interior, this may cause sparking.

Place the food into the appliance without packaging. The packaged ready meals can be put into the appliance only when the packaging is microwave safe. Refer to Hints and tips, Microwave suitable cookware and materials section.

Do not cover the food when using Microwave combi functions. Refer to Daily use.

Do not use Microwave functions or Microwave combination functions when there is no food inside the appliance.

### Microwave cooking

Cover the food for cooking or reheating with microwave functions. If you want to keep a crust, cook food without a cover.

Do not overcook the dishes by setting the power and time too high. The food can dry out, burn or cause fire.

Do not use the appliance to cook eggs or snails in their shells, because they can burst. Pierce the yolk of fried egg before reheating it.

Pierce food with skin or peel several times before cooking.

Cut vegetables into similar-sized pieces.

After you turn off the appliance, take the food out and let it stand for a few minutes to allow the heat distribute evenly.

### Microwave defrosting

Place the frozen, unwrapped food on a small upturned plate with a container below it, or on a defrosting rack or plastic sieve so that the defrosting liquid can leak out.

Remove defrosted pieces subsequently.

To cook fruit and vegetables without defrosting them first, you can use a higher microwave power.











Turning improves the results. For sensitive foods such as meat, turn upside down twice during defrosting.











## 10.5 Microwave suitable cookware and materials

For the microwave use only suitable cookware and materials. Use below table as a reference.

Check the cookware / material / food container specification before use.

For other specific microwave cookware not listed in this table, follow manufacturer instructions.

Cookware / Material	 	   	   
Ovenproof glass and porcelain with no metal components, e.g. heat-proof glass	✓	✓	✓
Non-ovenproof glass and porcelain without any silver, gold, platinum or other metal decorations	✓	✗	✗
Glass and glass ceramic made of ovenproof / frost-proof material	✓	✓	✓
Ovenproof ceramic and earthenware without any quartz or metal components and glazes which contain metal	✓	✓	✓
Ceramic, porcelain and earthenware with unglazed bottom or with small holes, e.g. on handles	✗	✗	✗
Heat-resistant plastic up to 200 °C	✓	✓	✗
Cardboard, paper only	✓	✗	✗
Clingfilm	✓	✗	✗

Cookware / Material	 	   	   
Microwave clingfilm	✓	✓	✗
Roasting dishes made of metal, e.g. enamel, cast iron	✗	✗	✗
Baking tins, black lacquer or silicon-coated	✗	✗	✗
Baking tray	✗	✗	✗
Wire shelf	✓	✓	✓

## 10.6 Power settings

Below data is for guidance only.

### 800 - 1000 W

- Heating up liquids

### 600 - 700 W

- Simmering rice
- Cooking vegetables
- Popcorn

### 400 - 500 W

- Heating one-plate meals

- Simmering stews
- Defrosting and heating ready frozen meals

### 300 W

- Cooking / Heating delicate food
- Heating baby food
- Continuing cooking

### 100 - 200 W

- Defrosting bread, fruit, cakes, pastries, cheese, butter, meat and fish
- Melting chocolate and butter

## 11. CARE AND CLEANING

### WARNING!

Refer to Safety chapters.

### 11.1 Notes on cleaning

#### Cleaning agents

- Clean the front of the appliance only with a microfibre cloth with warm water and a mild detergent.
- Use a cleaning solution to clean metal surfaces.
- Clean stains with a mild detergent.

#### Everyday use

- Clean the interior of the appliance after each use. Fat accumulation or other residue may cause fire.
- Clean the appliance ceiling carefully from residue and fat.
- Do not store food in the appliance for longer than 20 minutes. Dry the interior of the appliance only with a microfibre cloth after each use.

### Accessories

- Clean all accessories after each use and let them dry. Use only a microfibre cloth with warm water and a mild detergent. Do not clean the accessories in a dishwasher.
- Do not clean the non-stick accessories using abrasive cleaner or sharp-edged objects.

### 11.2 Removing the shelf supports

Remove the shelf supports to clean the appliance.

1. Turn off the appliance and wait until it is cold.
2. Carefully pull the shelf supports up and out of the front catch.
3. Pull the supports out of the rear catch.

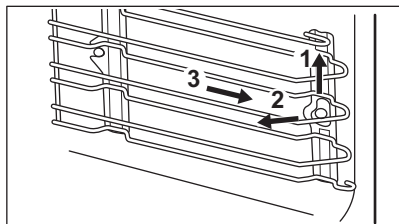

Install the shelf supports in the opposite sequence.

If the telescopic runners are supplied, its retaining pins must point to the front.

## 11.3 Replacing the lamp

### **WARNING!**

Risk of burns, the glass cover may be hot. Use protective glove when touching the lamp.

Only service is allowed to replace the lamp. Contact your Authorised Service Centre.

## 12. TROUBLESHOOTING

### **WARNING!**

Refer to Safety chapters.

### 12.1 What to do if...

Problem description	Cause and remedy
You cannot activate or operate the appliance.	The appliance is not connected to an electrical supply or it is connected incorrectly.
The appliance does not heat up.	The clock is not set. To set the clock refer to Clock functions.
	The door is not closed correctly.
	The fuse is blown. Make sure the fuse is the cause of the problem. If the problem recurs, contact a qualified electrician.
The lamp is turned off.	Child Lock is activated.
	The lamp is burnt out. Replace the lamp. For details refer to Care and cleaning.

### 12.2 Error codes

When the software error occurs, the display shows error message. You will find the list of problems in the table below. When the following error message continues to appear on the display, it means a faulty subsystem may have been disabled. In such a case contact your dealer or an Authorized Service Centre.

Code and description	Remedy
<b>F102</b> - the door is not fully closed or the door lock is broken.	Close the door. Turn the appliance off and on.
<b>F240, F439</b> - the touch fields on the display do not work properly.	Clean the surface of the display. Make sure there is no dirt on the touch fields.

Code and description	Remedy
<b>F908</b> - the appliance system cannot connect with the control panel.	Turn the appliance off and on.
<b>F131</b> - the temperature of magnetron sensor is too high. <b>1)</b>	Turn the appliance off and wait until it cools down. Turn the appliance on again.

**1)** If one of these errors occurs, the rest of the appliance functions will continue to work as usual.

### 12.3 Service data

If you cannot find a solution to the problem yourself, contact your dealer or an Authorised Service Centre.

The necessary data for the service centre is on the rating plate. The rating plate is located on the front frame of the appliance. It is visible when you open the door. Do not remove the rating plate from the appliance.

**We recommend that you write the data here:**

Model (MOD.):

Product number (PNC):

Serial number (S.N.):

## 13. ENERGY EFFICIENCY

### 13.1 Product information for power consumption and maximum time to reach applicable low power mode

Power consumption in standby	0.8 W
Maximum time needed for the equipment to automatically reach the applicable low power mode	20 min

### 13.2 Energy saving tips

Following tips below will help you save energy when using your appliance.

Make sure that the appliance door is closed when the appliance operates. Do not open the appliance door too often during cooking. Keep the door gasket clean and make sure it is well fixed in its position.

Use metal cookware and dark, non-reflective tins and containers to improve energy saving (only when you use a non-microwave function).

Do not preheat the appliance before cooking unless specifically recommended.

Keep breaks between baking as short as possible when you prepare a few dishes at one time.

#### Cooking with fan

When possible, use the cooking functions with fan to save energy.

#### Residual heat

When the cooking duration is longer than 30 min, reduce the appliance temperature to minimum 3 - 10 min before the end of cooking. The residual heat inside the appliance will continue to cook.

Use the residual heat to keep the food warm or warm up other dishes.

When you turn off the appliance, the display shows the residual heat or temperature.

If a programme with Duration is activated and the cooking time is longer than 30 min, the heating elements automatically turn off earlier in some appliance functions.

#### Keep food warm

Choose the lowest possible temperature setting to use residual heat and keep the food warm. The residual heat indicator or temperature appears on the display.

### **Cooking with the lamp off**

Turn off the lamp during cooking. Turn it on only when you need it.

## **14. ENVIRONMENTAL CONCERNS**

Recycle materials with the symbol . Put the packaging in relevant containers to recycle it. Help protect the environment and human health by recycling waste of electrical and electronic appliances. Do not dispose of

appliances marked with the symbol  with the household waste. Return the product to your local recycling facility or contact your municipal office.

**electrolux.com**

701138165-A-392025

