

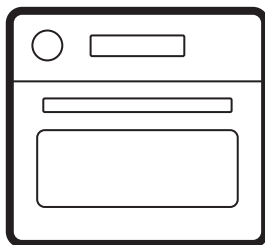

Electrolux



[electrolux.com/register](https://electrolux.com/register)



EVLDE46GK  
EVLDE46GX  
KVLFE46TGK  
KVLFE46TGX

# INSTALLATION

(\*mm)

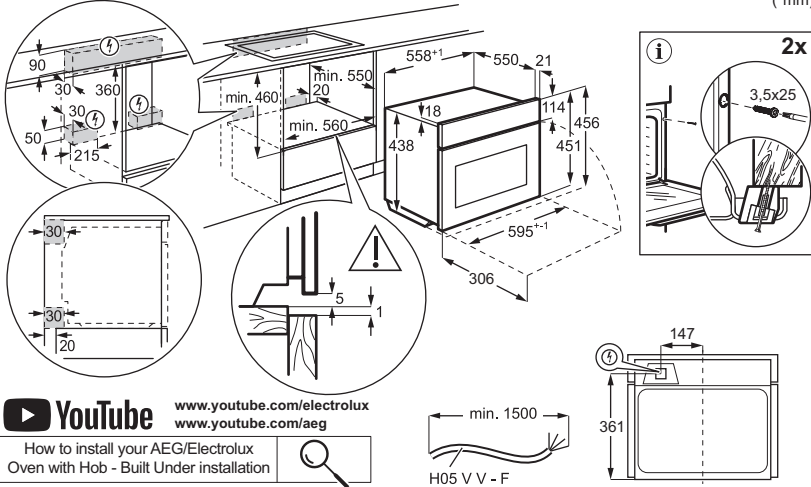

(\*mm)

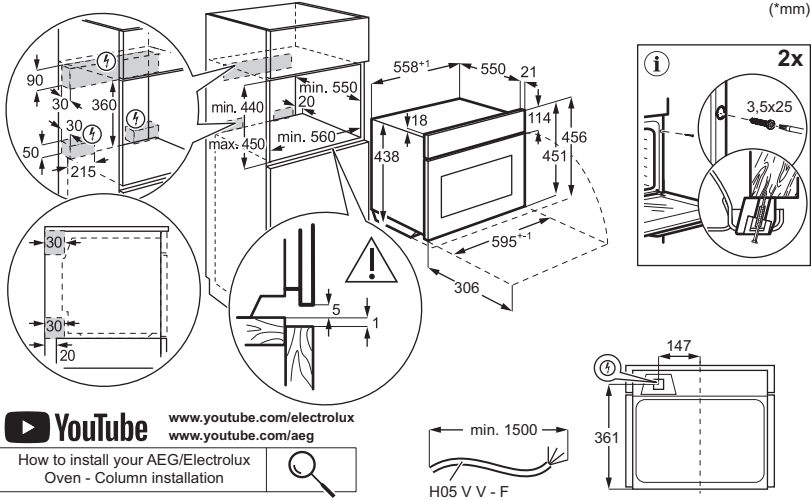

1. SAFETY INFORMATION.....	3
2. SAFETY INSTRUCTIONS.....	5
3. PRODUCT DESCRIPTION.....	7
4. BEFORE FIRST USE.....	8
5. DAILY USE.....	8

6. HINTS AND TIPS.....	12
7. CARE AND CLEANING.....	15
8. TROUBLESHOOTING.....	15
9. ENERGY EFFICIENCY.....	16
10. ENVIRONMENTAL CONCERNS.....	16

## 1. SAFETY INFORMATION

Before the installation and use of the appliance read the supplied instructions carefully. The manufacturer is not responsible for any injuries or damage that result from incorrect installation or usage. Always keep the instructions in a safe and accessible location for future reference.

### 1.1 Children and vulnerable people safety

- This appliance can be used by children aged from 8 years and above and persons with reduced physical, sensory or mental capabilities or lack of experience and knowledge if they have been given supervision or instruction concerning the use of the appliance in a safe way and understand the hazards involved. Children of less than 8 years of age and persons with very extensive and complex disabilities shall be kept away

- from the appliance unless continuously supervised.
- Children should be supervised to ensure that they do not play with the appliance.
- Keep packaging away from children and dispose of it properly.
- **WARNING:** The appliance and its accessible parts become hot during use. Keep children and pets away during use and cooling.
- Activate the child safety device, if available.
- Children must not clean or maintain the appliance without supervision.

### 1.2 General Safety

- This appliance is for cooking purposes only.
- This appliance is designed for single household domestic use in an indoor environment.
- This appliance may be used in offices, hotel guest rooms, bed & breakfast guest rooms, farm guest

houses, and other similar accommodation where such use does not exceed average domestic usage levels.

- Do not use the appliance before installing it in the built-in structure.
- Disconnect the appliance from the power supply before carrying out any maintenance.
- If the supply cord is damaged, it must be replaced by the manufacturer, its authorised service centre or similarly qualified persons to avoid an electrical hazard.
- **WARNING:** Ensure that the appliance is switched off before replacing the lamp to avoid the possibility of electric shock.
- **WARNING:** The appliance and its accessible parts become hot during use. Care should be taken to avoid touching heating elements or the surface of the appliance cavity.
- Always use oven gloves to remove or insert accessories or ovenware.
- Do not activate the microwave function when the appliance is empty to avoid electric arcing.
- Do not use metallic containers for food and beverages during microwave cooking unless specified by the manufacturer.
- **WARNING:** If the door or door seals are damaged, do not operate the appliance until repaired by a qualified person.
- **WARNING:** Only a qualified person should perform service or repair operations involving the removal of covers protecting against microwave energy exposure.
- **WARNING:** Do not heat liquids or foods in sealed containers to prevent explosions.
- Use only utensils suitable for microwave ovens.
- Observe the appliance when heating food in plastic or paper containers to prevent ignition.
- The appliance is intended for heating food and beverages. Drying of food or clothing and heating of warming pads, slippers, sponges, damp cloth and similar may lead to risk of injury, ignition or fire.
- If smoke is emitted, switch off or unplug the appliance

and keep the door closed in order to stifle any flames.

- Microwave heating of beverages can result in delayed eruptive boiling. Care must be taken when handling the container.
- Stir or shake the contents of feeding bottles and baby food jars and check the temperature before consumption to avoid burns.
- Do not heat eggs in their shells or whole hard-boiled eggs as they may explode, even after microwave heating has ended.
- To remove the shelf supports first pull the front of the shelf support and then the rear end away from the side walls. Install the shelf

supports in the opposite sequence.

- Clean the appliance regularly and remove any food deposits.
- Do not use a steam cleaner to clean the appliance.
- Do not use harsh abrasive cleaners or sharp metal scrapers to clean the glass door since they can scratch the surface, which may result in shattering of the glass.
- Failure to maintain the appliance in a clean condition could lead to deterioration of the surface that could adversely affect the life of the appliance and possibly result in a hazardous situation.

## 2. SAFETY INSTRUCTIONS

### 2.1 Installation

#### **WARNING!**

Only a qualified person must install this appliance.

- Remove all the packaging.
- Do not install or use a damaged appliance.
- Follow the installation instructions available on our website.
- Be careful when moving the appliance, as it is heavy. Use safety gloves and enclosed footwear.
- Do not pull the appliance by the handle.
- Install the appliance in a safe and suitable location that meets installation requirements.
- Keep the minimum distance from other appliances and units.

- Before mounting the appliance, ensure it is level and that the door opens without any restraint.
- The appliance is equipped with an electric cooling system. It must be operated with the electric power supply.

### 2.2 Electrical connection

#### **WARNING!**

Risk of fire and electric shock.

- All electrical connections should be made by a qualified electrician.
- Make sure the parameters on the rating plate are compatible with the electrical ratings of the mains power supply.
- The appliance must be earthed. Always use a correctly installed shockproof socket.

- Do not use multi-plug adapters and extension cables.
- Avoid damaging the mains plug and cable. If replacement is needed, it must be done by our Authorized Service Centre.
- Do not let mains cables touch or come near the appliance door or the niche below, especially when it operates or the door is hot.
- Shock protection of live and insulated parts must be fastened securely and should not be removable without tools.
- Connect the mains plug to the socket only at the end of installation. Ensure access to the mains plug after installation.
- If the mains socket is loose, do not connect the mains plug.
- Do not disconnect the appliance by pulling on the mains cable. Always pull on the mains plug.
- Use only correct isolation devices: line protecting cut-outs, fuses (screw type fuses removed from the holder), earth leakage trips and contactors.
- The electrical installation must have an isolation device that disconnects the appliance from the mains at all poles, with a contact opening width of at least 3 mm.
- This appliance is supplied only with a main cable.

### 2.3 Use

#### **WARNING!**

Risk of injury, burns and electric shock or explosion.

- Do not change the specification of the appliance.
- Ensure ventilation openings are not blocked.
- Do not let the appliance stay unattended during operation.
- Deactivate the appliance after each use.
- Be careful when opening the appliance door during operation, as hot air and flammable mixtures from alcohol ingredients can be released.
- Do not operate the appliance with wet hands or when it comes in contact with water.
- Do not apply pressure on the open door.
- Do not use the appliance as a work surface or as a storage surface.
- Keep sparks and open flames away from the appliance when the door is open.
- Do not place flammable products near the appliance.

- Do not use microwave function to preheat the appliance.

#### **WARNING!**

Risk of damage to the appliance.

- To prevent damage or discoloration to the enamel:
  - do not place aluminum foil directly on the cavity bottom.
  - do not put water directly into the hot appliance.
  - do not leave moist dishes and food in the appliance after cooking.
  - be careful when removing or installing accessories.
- Enamel or stainless steel discoloration does not affect performance of the appliance.
- Use a deep pan for moist cakes, as fruit juices can cause permanent stains.
- Use only accessories supplied with this appliance or recommended by the manufacturer.
- Always cook with the appliance door closed.
- If the appliance is installed behind a furniture panel, do not close the panel during use or until the appliance is fully cooled to prevent heat and moisture damage.
- Concerning the lamp(s) inside this product and spare part lamps sold separately: These lamps are intended to withstand extreme physical conditions in household appliances, such as temperature, vibration, humidity, or are intended to signal information about the operational status of the appliance. They are not intended to be used in other applications and are not suitable for household room illumination.
- This product contains a light source of energy efficiency class G.
- Use only lamps with the same specifications.
- To repair the appliance contact the Authorised Service Centre. Use original spare parts only.

### 2.4 Care and cleaning

#### **WARNING!**

Risk of injury, fire, or damage to the appliance.

- Turn off the appliance before maintenance.

- Ensure the appliance is cold to avoid glass breakage. If the door glass panels are damaged, contact the authorized service centre for replacement.
- Clean and dry the appliance, its cavity, and accessories after each use to prevent steam condensation, corrosion, and surface deterioration.
- Fat and food remaining in the appliance can cause fire and electrical arcing when the microwave function operates.
- Use a microfibre cloth, warm water, and neutral detergents for cleaning the appliance and accessories. Do not use abrasive products, pads, solvents, sharp-edged or metal objects.

- Follow safety instructions on packaging when using an oven spray.

## 2.5 Disposal

### **WARNING!**

Risk of injury or suffocation.

- Contact your municipal authority for information on how to dispose of the appliance.
- Disconnect the appliance from the mains, then cut off and dispose of the electrical cable.

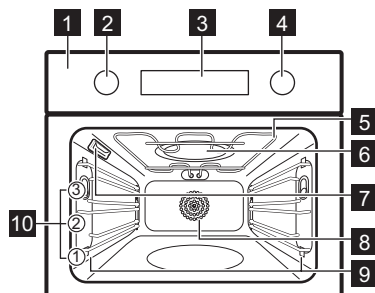

## 3. PRODUCT DESCRIPTION

### 3.1 General overview



- 1** Control panel
- 2** Knob for the heating functions
- 3** Display
- 4** Control knob
- 5** Heating element
- 6** Microwave generator
- 7** Lamp
- 8** Fan
- 9** Shelf support, removable
- 10** Shelf positions

### 3.2 Control panel

-  Press to set timer functions.
-  Press to set: Fast Heat Up.
-  Press to turn the appliance lamp on and off.

---









**WATT** Press to set: Microwave power.

---

**OK** Press to confirm your selection.

---

### Display indicators

-  The appliance is locked.
-  Submenu: Assisted Cooking.
-  Submenu: Settings
-  Microwave function is activated.
-  Minute minder is activated.
-  Cooking time is activated.
-  Time Delayed Start is activated.
-  Optimer is activated.

---

 Progress bar - visually indicates when the appliance reaches the set temperature or when the cooking time comes to an end.

---

### To turn on the appliance:

1. Press the knobs. The knobs come out (selected models only).
2. Turn the knob for the heating functions to select a function.
3. Turn the control knob to adjust settings.

To turn off the appliance: turn the knob for the heating functions to the off position **0**.

## 4. BEFORE FIRST USE



### 4.1 Setting the time

After the first connection to the mains, wait until the display shows: "00:00" or "12:00" (depending on the model).

1. Turn the control knob to set the time.
2. Press OK.

### 4.2 Initial preheating and cleaning

1. Preheat the empty appliance to remove any odours. Ventilate the room.

2. Remove all accessories and shelf supports.
3. Set each function to maximum temperature and let the appliance operate for specified durations:  1 h,  15 min,  15 min. Refer to Daily use.
4. Turn off the appliance and let it cool down.
5. Clean with a microfiber cloth, warm water, and mild detergent. Replace accessories and shelf supports.

## 5. DAILY USE

### 5.1 Heating functions

#### Standard heating functions



**True Fan Cooking:** Even baking, tenderness, drying



**Conventional Cooking:** Traditional baking



**Pizza Function:** Baking pizza



**Turbo Grilling:** Roasting meat, browning

#### Microwave functions



**Defrost:** Defrosting various types of food, power range: 100 - 200 W



**Reheat:** Heating up pre-prepared meals, power range: 300 - 700 W



**Microwave:** Heating up, cooking, power range: 100 - 1000 W

#### Microwave combi functions



**Turbo Grilling + MW:** Roasting large pieces, baking gratins, power range: 100 - 400 W.



**True Fan Cooking + MW:** Baking, power range: 100 - 400 W.

The lamp may turn off automatically at a temperature below 80°C during some oven functions.

There are additional heating functions available under the Assisted Cooking. Refer to Daily use, Submenu: Assisted Cooking.

### 5.2 Setting: Heating functions

1. Turn the knob for the heating functions to select a heating function.
2. Turn the control knob to set the temperature.

3. Press OK.

 Fast Heat Up - press and hold to shorten the heating time. It is available for some heating functions. Fan may turn on automatically.

### 5.3 Timer

1. Turn the knobs to select the heating function and to set the temperature, if needed.
2. Press  until the display shows a desired timer function:

 **Minute minder:** Set a countdown. When the timer ends, the signal sounds.

 **Cooking time<sup>1)</sup>:** Set a countdown. When the timer ends, the signal sounds and the cooking stops.

 **Time Delayed Start<sup>2)</sup>:** To postpone the start and / or end of cooking.

3. Turn the control knob to set the time.
4. Press OK.

<sup>1)</sup> This function is available only for: True Fan Cooking, Conventional Cooking, Turbo Grilling, Pizza Function, Turbo Grilling + MW, True Fan Cooking + MW.

<sup>2)</sup> This function is available only for: True Fan Cooking, Conventional Cooking, Turbo Grilling, Pizza Function.

- When the time ends, press **OK** and turn the knobs to the off position, if needed.

## 5.4 Setting: Microwave functions/ Microwave combi functions

Microwave combi functions combine standard heating functions with microwave boost to shorten cooking time and improve cooking results.

- Remove all accessories, except the wire shelf.
- Place the food in the appliance.
- Turn the knob for the heating functions to select the function.

Microwave functions: The display shows duration and microwave power.

Microwave combi functions: The display shows temperature and microwave power.

- Press **OK** to start with default settings.
- To adjust the duration/temperature turn the control knob. Press **OK**.
- To adjust the microwave power press **WATT** and turn the control knob. Press **OK**.

You can adjust settings while cooking.

If you open the door, the microwave function stops. To start it again, close the door. Press **OK**.

## 5.5 Entering: Menu

Open the Menu to access additional heating functions, Assisted Cooking dishes and settings.

- Turn the knob for the heating functions to .

The display shows  .

- Turn the control knob and select the icon to enter submenu. Press **OK**.

## 5.6 Setting: Assisted Cooking

Assisted Cooking submenu consists of a set of additional heating functions and programmes that are designed for dedicated dishes. Programmes start with a suitable setting. You can adjust the time, temperature and if available microwave power during cooking.

- Turn the knob for the heating functions to .





- Turn the control knob to select . Press **OK**.
- Turn the control knob to select a function (F1 - F...) or a dish (P1 - P...). Press **OK**.
- Turn the control knob to adjust the weight. Option is available for selected dishes. Press **OK**.
- Place the food inside the appliance. Press **OK**.
- When the function ends, check if the food is ready. Extend the cooking time, if needed.

### Submenu: Assisted Cooking

The display shows **F** and a **number** of the function that you can check in the table.

<b>F1</b>	<b>Grill:</b> To grill thin pieces of food and to toast bread.
<b>F2</b>	<b>Bottom Heat:</b> To bake cakes with crispy bottom and to preserve food.
<b>F3</b>	<b>Frozen Foods:</b> To make convenience food crispy, e.g. french fries, potato wedges or spring rolls.
<b>F4</b>	<b>Conventional Cooking + MW:</b> Baking and roasting food on one shelf position. The function with MW boost, power range: 100 - 400 W.
<b>F5</b>	<b>Grill + MW:</b> To grill and brown food on one shelf position. Function with MW boost, power range: 100 - 400 W.

### Legend

	Weight adjustment available.
	Function with microwave power. Use microwave safe accessory.
	Preheat the appliance before you start cooking.
	Shelf level. Refer to Product description.

The display shows **P** and a **number** of the dish that you can check in the table.

<b>P1</b>	<b>Roast beef, rare</b>	1000 - 1500 g; 4 - 6 cm thick
<b>P2</b>	<b>Roast beef, medium</b>	 <b>1; baking tray</b> Fry the meat for a few minutes in a hot pan.
<b>P3</b>	<b>Roast beef, well-done</b>	Insert to the appliance.

P4	<b>Steak, medium.</b> 150 - 300 g per piece; 3 cm thick ☐ 2; <b>baking tray</b> Fry the meat for a few minutes in a hot pan. Insert to the appliance.
P5	<b>Beef roast / braised</b> (prime rib, thick flank), 1500 - 2000 g ☐ ☐ 2; <b>roasting dish on wire shelf</b> Fry the meat for a few minutes in a hot pan. Add liquid. Insert to the appliance.
P6	<b>Roast beef, rare<sup>1)</sup></b> 1000 - 1500 g; 4 - 6 cm thick
P7	<b>Roast beef, medium<sup>1)</sup></b> ☐ 1; <b>baking tray</b> Fry the meat for a few minutes in a hot pan. Insert to the appliance.
P8	<b>Roast beef, well-done<sup>1)</sup></b> ☐ 1; <b>baking tray</b> Fry the meat for a few minutes in a hot pan. Insert to the appliance.
P9	<b>Fillet, rare<sup>1)</sup></b> 800 - 1000 g; 5 - 6 cm thick
P10	<b>Fillet, medium<sup>1)</sup></b> ☐ 2; <b>baking tray</b> Fry the meat for a few minutes in a hot pan. Insert to the appliance.
P11	<b>Fillet, well-done<sup>1)</sup></b> ☐ 2; <b>baking tray</b> Fry the meat for a few minutes in a hot pan. Insert to the appliance.
P12	<b>Veal roast</b> (e.g. shoulder), 800 - 1500 g; 5 - 6 cm thick ☐ ☐ 1; ceramic or glass casserole dish on <b>wire shelf</b> Fry the meat for a few minutes in a hot pan. Add liquid. Insert to the appliance.
P13	<b>Pork roast</b> (e.g. neck or shoulder), 1500 - 2000 g ☐ ☐ 1; ceramic or glass casserole dish on <b>wire shelf</b>
P14	<b>Pulled pork</b> , 1500 - 2000 g <sup>1)</sup> ☐ 1; ceramic or glass casserole dish on <b>wire shelf</b>
P15	<b>Pork loin, fresh</b> , 1000 - 1500 g; 6 - 7 cm thick ☐ 1; ceramic or glass casserole dish on <b>wire shelf</b> Fry the meat for a few minutes in a hot pan. Insert to the appliance.
P16	<b>Spare ribs</b> , 2000 - 3000 g; use raw, 2 - 3 cm thin ☐ 2; <b>baking tray</b>

P17	<b>Lamb leg with bones</b> , 500 - 1000 g; 7 - 9 cm thick ☐ 1; ceramic or glass casserole dish on <b>wire shelf</b> Fry the meat for a few minutes in a hot pan. Add liquid. Insert to the appliance.
P18	<b>Chicken, whole</b> , 1000 - 1400 g ☐ ☐ 1; <b>wire shelf</b> with plate placed directly in centre of cavity bottom Place the chicken directly on the wire shelf with breast side down. After 30 min, turn the chicken upside down.
P19	<b>Chicken, half</b> , 500 - 800 g ☐ ☐ 1; <b>baking tray</b>
P20	<b>Chicken breast</b> , 180 - 250 g per piece ☐ 2; casserole dish on <b>wire shelf</b> Fry the meat for a few minutes in a hot pan. Insert to the appliance.
P21	<b>Chicken legs, fresh</b> , 250 - 350 g ☐ 1; <b>baking tray</b>
P22	<b>Duck, whole</b> , 1500 - 2500 g ☐ ☐ 1; <b>baking tray</b> Turn the duck after half of the cooking time.
P23	<b>Goose breast</b> , 350 - 500 g ☐ 1; ceramic or glass casserole dish on <b>wire shelf</b>
P24	<b>Meat loaf</b> , 1000 - 1500 g ☐ 1; loaf pan on <b>wire shelf</b>
P25	<b>Meatloaf, Leberkäse</b> , 750 - 1000 g ☐ 1; loaf pan on <b>wire shelf</b>
P26	<b>Fish, whole, grilled</b> , 500 - 1000 g per fish ☐ 1; <b>baking tray</b>
P27	<b>Fish fillet</b> , 150 - 300 g ☐ ☐ 2; ceramic or glass casserole dish on <b>wire shelf</b>
P28	<b>Cheesecake</b> , 2000 - 3000 g ☐ 2; <b>baking tray</b>
P29	<b>Apple cake, covered</b> , 1000 - 1500 g ☐ ☐ 2; pie pan on <b>wire shelf</b>
P30	<b>Apple tart</b> , 1000 - 1500 g ☐ 2; tart pan on <b>wire shelf</b>
P31	<b>Apple pie</b> , 1000 - 1200 g ☐ ☐ 1; pie pan on <b>wire shelf</b>

P32	<b>Brownies</b> , 1000 g of dough 2; casserole dish on <b>wire shelf</b>
P33	<b>Muffins</b> , 10 to 20 pieces 2; <b>baking tray</b>
P34	<b>Loaf cake</b> , 1000 g of dough 1; loaf pan on <b>wire shelf</b>
P35	<b>Baked potatoes</b> , 1000 g of fresh potatoes 2; <b>baking tray</b>
P36	<b>Wedges</b> , 750 - 1000 g of raw potatoes 2; <b>baking tray</b> lined with baking paper
P37	<b>Grilled mixed vegetables</b> , 1000 - 1500 g 1; <b>baking tray</b> lined with baking paper
P38	<b>Croquettes</b> (frozen), 500 - 750 g 2; <b>baking tray</b> lined with baking paper
P39	<b>French fries</b> (frozen), 750 g 2; <b>baking tray</b> lined with baking paper
P40	<b>Lasagna</b> with dry pasta sheets, 1000 - 1500 g 1; casserole dish on <b>wire shelf</b>
P41	<b>Potato gratin</b> (raw potatoes), 1000 - 1500 g 1; casserole dish on <b>wire shelf</b>
P42	<b>Pizza fresh, thin crust</b> 1; <b>baking tray</b> lined with baking paper
P43	<b>Pizza fresh, thick crust</b> 1; <b>baking tray</b> lined with baking paper
P44	<b>Quiche lorraine</b> , 4.5 cm thick 1; springform tin on <b>wire shelf</b>
P45	<b>Baguette / Ciabatta / White bread</b> , 600 - 800 g of fresh dough 2; <b>baking tray</b> lined with baking paper

**P46** **Whole grain / Rye / Dark bread**, 1000 g of fresh dough  
 1; **baking tray** lined with baking paper

1) Low temperature cooking.

## 5.7 Changing: Settings

- Turn the knob for the heating functions to .
- Turn the control knob to select . Press **OK**.
- Turn the control knob to select the setting. Press **OK**.
- Turn the control knob to adjust the value. Press **OK**.
- Turn the knob for the heating functions to the off position to exit Menu.

### Submenu: Settings

Setting	Value
<b>01</b> Time of day	Change
<b>02</b> Display brightness	1 - 5
<b>03</b> Key tones	1 - Beep, 2 - Click, 3 - Sound off
<b>04</b> Buzzer volume	1 - 4
<b>05</b> Uptimer	On / Off
<b>06</b> Light	On / Off
<b>07</b> Fast Heat Up	On / Off
<b>08</b> Demo mode	Activation code: 2468
<b>09</b> Software version	Check
<b>10</b> Reset all settings	Yes / No

## 5.8 Lock

This function prevents an accidental change of the appliance function.

When activated while the appliance is in use, it locks the control panel, ensuring that the current cooking settings continue uninterrupted.

When activated while the appliance is off, it keeps the control panel locked, preventing

the appliance from being turned on unintentionally.

⏻ OK - press and hold to turn on and off the function.

A signal sounds.  - flashes 3 times when the lock is turned on.

## 5.9 Accessories



Accessories available depending on model. Scan the QR code to check how to use accessories supplied with your appliance. You can order optional accessories separately. For more information, please contact your local supplier.

Use only suitable cookware and material. Refer to Hints and tips chapter, Microwave suitable cookware and materials.

A small indentation at the top increases safety and provides tilt protection. The rim around the shelf prevents cookware from slipping off the shelf.

Insert the accessory (wire shelf / tray) between the guide bars of the shelf support. Make sure that the shelf touches the back of the oven interior and the feet point down.

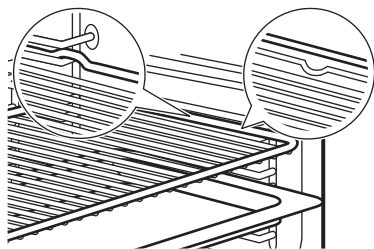

If your tray has a slope, position it towards the back of the oven interior.

If your wire shelf has a step, position it towards the front of the oven interior.

If there is an inscription on the accessory, make sure it is facing you.

## 6. HINTS AND TIPS

### 6.1 Cooking recommendations

The temperature and cooking times in the tables are for guidance only. They depend on the recipes, quality and quantity of the ingre-

If you are using a tray with holes, place the tray / pan underneath to collect dripping liquids.

## 5.10 Trivet and Grill- / Roasting pan

### WARNING!

Be careful when you remove the accessories from a hot appliance. There is a risk of burns.

You can use the trivet to roast larger pieces of meat or poultry on one shelf position.

1. Put the trivet into the deep pan so that the supports of the wire shelf point up.

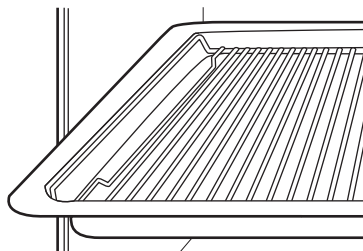

2. Put the deep pan into the appliance on the necessary shelf position.

You can use the trivet to grill flat dishes in large quantities and to toast.

1. Put the trivet into the deep pan so that the supports of the wire shelf point down.

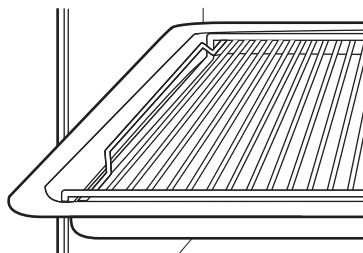







2. Put the deep pan into the appliance on the necessary shelf position.

ients used. If you cannot find the settings for a specific recipe, look for a similar one.

Cooking and baking processes are only suitable on one level.

Count the shelf positions from the bottom of the oven floor.













## Symbols used in the tables:

	Food type
	Heating function
	Temperature
	Microwave power (W)
	Shelf position
	Cooking time (min)
	Additional information

## 6.2 Information for test institutes

### Baking on one level













Tests according to EN 60350-1, IEC 60350-1.

					
Small cakes, 20 per tray					
	2	150	18 - 28	1) 2)	
	2	150	18 - 28	1) 2)	
Fatless sponge cake					
	1	170	25 - 35	3) 4)	
	1	170	28 - 38	3) 4)	
Shortbread					
	2	140	28 - 38	1) 2)	
	2	140	25 - 35	1) 2)	
Apple pie					
	1	170	65 - 75	3) 4)	
	1	170	57 - 67	3) 4)	
Toast					
<b>F1</b>	2	230	7 - 12	3) 2) 5)	

- 1) Use the baking tray with the slope towards the back of the oven interior. It must touch the fan cover.
- 2) Preheat the appliance until set temperature is reached. Do not use the function: Fast Heat Up.
- 3) Use wire shelf.
- 4) 2 tins placed diagonally (Ø 20 cm). The right one to be positioned more in the front than the left one.
- 5) According to: IEC 60350-1:2016 and IEC 60350-1:2023.









## Microwave and microwave combi functions













Tests according to EN 60705, IEC 60705.

						
Sponge cake						
	1	500	-	8 - 10	1) 2)	
Meatloaf						
	1	300	-	30 - 35	1) 2) 3)	
Egg custard						
	1	400	-	18 - 23	1) 4)	
Defrosting minced meat (500 g)						
	1	200	-	7 - 8	1) 5)	
Cake						
<b>F4</b>	1	200	170	22 - 27	1) 4)	
Potato gratin						
	1	200	180	35 - 40	1) 6)	
Chicken (1100 g)						
	1	200	200	30	1) 7)	
		-		18 - 23		

- 1) Use wire shelf. It must touch the fan cover.
- 2) Turn container around by 1/2, halfway through the cooking time.
- 3) Use MW suitable clingfilm during cooking. Prick the clingfilm several times before cooking.
- 4) Do not turn the food during the cooking process.
- 5) Turn the meat upside down over the longest side, one time after 1/3 and a second time after 2/3 of the elapsed cooking time.
- 6) Turn container clockwise by 1/4, halfway through the cooking time.
- 7) Place a plate at the bottom of the oven. Place chicken directly on wire shelf with breast side down. After 30 min, turn the chicken upside down and change the heating function to: Turbo Grilling.

### Additional recipes

						
Meringues						
	2	-	100	90 - 180	1) 2) 3)	
	2	-	100	90 - 180	1) 2) 3)	
Scones						

					
	3	-	200	11 - 13	1) 3)
	3	-	190	10 - 12	1) 3)
Chicken					
	1	-	200	65 - 75	1) 4)
Popcorn					
	-	700	-	3 - 4	5) 6)
Plated meals, chilled (1 portion)					
	1	500	-	7 - 9	7) 8) 9)
Liquids in baby bottles					
	-	1000	-	0.5	10)
Lasagne, frozen (400 g)					
	1	100	210	23 - 28	7) 11)
Lasagne, frozen (600 g)					
<b>F4</b>	1	200	190	48 - 53	7) 11)
Pizza, frozen					
<b>F4</b>	1	200	210	12 - 16	7) 11)

1) Use baking tray with the slope towards the back of the oven interior.

2) Use baking paper.

3) Preheat the appliance until set temperature is reached. Do not use the function: Fast Heat Up.

4) Place chicken with breast side down. Turn it upside down halfway through the cooking time.

5) Use flat ceramic plate on the cavity bottom.

6) The bag should be taken out of the appliance when the kernels stop popping.

7) Use wire shelf. It must touch the fan cover.

8) Cover the food with a microwavable plastic lid.

9) Turn container around by 1/2, halfway through the cooking time.

10) Position the bottle in the centre of the cavity bottom without using any accessories.

11) Do not turn the food during the cooking process.

### 6.3 Microwave recommendations

Place the food in the centre of the wire shelf. Use first shelf position.

Turn or stir food halfway through cooking.

Stir liquid dishes occasionally and before serving.

When heating liquids, place a spoon in the cup to improve heat distribution and prevent

overboiling. The spoon must not touch the oven interior to avoid sparking.

Do not cover food when using Microwave combi functions. Refer to Daily use.

Do not use Microwave or Microwave Combi functions without food inside the appliance.

#### Microwave cooking

Cover food when cooking or reheating. To keep a crust, cook without a cover.

Do not set the power or time too high to avoid drying, burning or fire.

Do not cook eggs or snails in shells; they can burst. Pierce the yolk of a fried egg before reheating.

Pierce food with skin or peel several times before cooking.

Cut vegetables into similar-sized pieces.

After cooking, let food stand for a few minutes for even heat distribution.

#### Microwave defrosting

Place the frozen, unwrapped food on a small upturned plate with a container below it, or on a defrosting rack or plastic sieve so liquids can drain

Remove defrosted pieces as they thaw.

To cook fruit and vegetables without defrosting, use a higher microwave power.





Turning improves results. For sensitive foods like meat, turn them upside down twice during defrosting.

### 6.4 Microwave suitable cookware and materials





For the microwave use only suitable cookware and materials. Use below table as a reference.

Check the cookware / material / food container specification before use.

For other specific microwave cookware not listed in this table, follow manufacturer instructions.

Cookware / Material						1)
Ovenproof glass and porcelain with no metal parts	✓	✓	✓			
Non-ovenproof glass and porcelain without metal decorations	✓	X	X			

Cookware / Material	   
Ovenproof/frost-proof glass and glass-ceramic	✓ ✓ ✓ 1)
Ovenproof ceramic and earthenware without quartz or metal components or metal-containing glazes	✓ ✓ ✓
Ceramic, porcelain and earthenware with unglazed bottom or with small holes, e.g. on handles	X X X
Heat-resistant plastic up to 200°C	✓ ✓ X
Cardboard, paper only	✓ X X
Clingfilm	✓ X X
Microwave clingfilm	✓ ✓ X
Metal roasting dishes (e.g., enamel, cast iron)	X X X
Baking tins, black lacquer or silicon-coated	X X X
Baking tray	X X X

Cookware / Material	   
Wire shelf	✓ ✓ ✓ 1)

1) Cookware and materials apply also to functions: Conventional Cooking + MW, Grill + MW. Refer to "Daily use, Setting: Assisted Cooking.

## 6.5 Power settings

Below data is for guidance only.

800 - 1000 W

- Heating up liquids

600 - 700 W

- Simmering rice
- Cooking vegetables
- Popcorn

400 - 500 W

- Heating one-plate meals
- Simmering stews
- Defrosting and heating ready frozen meals

300 W

- Cooking / Heating delicate food
- Heating baby food
- Continuing cooking

100 - 200 W

- Defrosting bread, fruit, cakes, pastries, cheese, butter, meat and fish
- Melting chocolate and butter

## 7. CARE AND CLEANING

### 7.1 Notes on cleaning

- Use a cleaning solution for metal surfaces.
- Use the liquid descaler recommended by the manufacturer to remove limestone residue.
- Do not store food in the appliance for longer than 20 minutes.
- Do not clean the accessories in a dishwasher.

### 7.2 Removing the shelf supports

1. Make sure the appliance is cold.

2. Carefully pull the shelf supports up and out of the front catch.
3. Pull the supports out of the rear catch.
4. Put the shelf supports back to the initial position. Repeat the steps in the reverse order.

If the telescopic runners are supplied, their retaining pins must point to the front.

### 7.3 Replacing the lamp

Only service is allowed to replace the lamp. Contact your Authorised Service Centre.

## 8. TROUBLESHOOTING

If you cannot find a solution to the problem yourself, contact your dealer or an Authorised Service Centre. Service details are on the rat-

ing plate, located on the front frame. It is visible when you open the door. Do not remove the rating plate.

If the display shows an error code that is not in this table, turn the house fuse off and on to restart the appliance. If the error code recurs contact an Authorised Service Centre.

**You cannot activate or operate the appliance.** - The appliance is not connected to an electrical supply or it is connected incorrectly.

**The appliance does not heat up.**

- Lock is activated.
- Automatic switch-off is activated.

**The lamp does not work.** - The lamp is burnt out. Lamp needs to be replaced, contact an Authorised Service Centre.

**The display shows "00:00".** - There was a power cut. Set the time of day.

## 9. ENERGY EFFICIENCY

### 9.1 Information requirements according to (EU) No 2023/826

Power consumption in standby	0.8 W
Maximum time needed for the equipment to automatically reach the applicable low power mode	20 min

Appliance tested according to: EN 50564.

### 9.2 Energy saving tips

- Keep the door closed during cooking and avoid opening it often.
- Keep the door gasket clean and make sure it is well fixed in its position.
- Use metal or dark, non-reflective cookware (only when you use a non-microwave function).
- Skip preheating unless needed.
- Minimize breaks between baking multiple dishes.
- When possible, use the cooking functions with fan to save energy (selected models only).
- Use residual heat to keep food warm. Reduce the appliance temperature to minimum 3 - 10 min before the end of cooking.

- Turn off the lamp during cooking unless needed.
- Moist Fan Baking (selected models only) - this function was used to comply with the energy efficiency class and ecodesign requirements (according to EU 65/2014 and EU 66/2014). Tests according to: IEC/EN 60350-1. The oven door should be closed during cooking so that the function is not interrupted and the oven operates with the highest energy efficiency possible. When you use this function the lamp automatically turns off. In some models it takes 30 sec.
- Automatic switch-off - for safety reasons, if the heating function is active and no settings are changed, the appliance will turn off automatically after a certain period of time. If you intend to run a heating function for a duration exceeding the automatic switch-off time, set the cooking time.
  - 12.5 h: 30-115 °C
  - 8.5 h: 120-195 °C
  - 5.5 h: 200-245 °C
  - 3 h: 250-maximum °C

## 10. ENVIRONMENTAL CONCERNS

Recycle materials with the symbol . Put the packaging in relevant containers to recycle it. Help protect the environment and human health by recycling waste of electrical and electronic appliances. Do not dispose of ap-

pliances marked with the symbol  with the household waste. Return the product to your local recycling facility or contact your municipal office.

